



**INTERCONNECTION
FACILITIES STUDY
REPORT**

GEN-2018-009

Published February 2024

By SPP Generator Interconnections Dept.

REVISION HISTORY

DATE OR VERSION NUMBER	AUTHOR	CHANGE DESCRIPTION
February 20, 2024	SPP	Initial draft report issued.
March 5, 2024	SPP	Final report issued.
October 2, 2024	SPP	Table 4 updated to reflect restudy results.

CONTENTS

Revision History	i
Summary	1
Introduction	1
Phase(s) of Interconnection Service	1
Compensation for Amounts Advanced for Network Upgrade(s).....	1
Interconnection Customer Interconnection Facilities	2
Transmission Owner Interconnection Facilities and Non-Shared Network Upgrade(s)	3
Shared Network Upgrade(s)	4
Contingent Network Upgrade(s).....	5
Affected System Upgrade(s)	6
Conclusion.....	7
Appendices	8
A: Transmission Owner’s Interconnection Facilities Study Report and Network Upgrades Report(s).....	9

SUMMARY

INTRODUCTION

This Interconnection Facilities Study (IFS) for Interconnection Request GEN-2018-009 is for a 150 MW generating facility located in Seward/Meade, KS. The Interconnection Request was studied in the DISIS-2018-001 Impact Study for ER. The Interconnection Customer's requested in-service date is December 15, 2026.

The interconnecting Transmission Owner, Sunflower Electric Power Corporation (SUNC), performed a detailed IFS at the request of SPP. The full report is included in Appendix A. SPP has determined that full Interconnection Service will be available after the assigned Transmission Owner Interconnection Facilities (TOIF), Non-Shared Network Upgrades, Shared Network Upgrades, Contingent Network Upgrades, and Affected System Upgrades that are required for full interconnection service are completed.

The primary objective of the IFS is to identify necessary Transmission Owner Interconnection Facilities, Network Upgrades, other direct assigned upgrades, cost estimates, and associated upgrade lead times needed to grant the requested Interconnection Service.

PHASE(S) OF INTERCONNECTION SERVICE

It is not expected that Interconnection Service will occur in phases. However, full Interconnection Service will not be available until all Interconnection Facilities and Network Upgrade(s) can be placed in service.

COMPENSATION FOR AMOUNTS ADVANCED FOR NETWORK UPGRADE(S)

FERC Order ER20-1687-000 eliminated the use of Attachment Z2 revenue crediting as an option for compensation. The Incremental Long Term Congestion Right (ILTCR) process will be the sole process to compensate upgrade sponsors as of July 1st, 2020.

INTERCONNECTION CUSTOMER INTERCONNECTION FACILITIES

The Generating Facility is proposed to consist of Fifty (50) 3.03 MW GE 3.0-140 Wind Turbines for a total generating nameplate capacity of 150 MW.

The Interconnection Customer's Interconnection Facilities to be designed, procured, constructed, installed, maintained, and owned by the Interconnection Customer at its sole expense include:

- 34.5 kV underground cable collection circuits;
- 34.5 kV to 115 kV transformation substation with associated 34.5 kV and 115 kV switchgear;
- One 115/34.5 kV 110/147/184 MVA (ONAN/ONAF/ONAF) step-up transformer to be owned and maintained by the Interconnection Customer at the Interconnection Customer's substation;
- An Approximately 13.5 miles overhead kV line to connect the Interconnection Customer's substation to the Point of Interconnection ("POI") at the 115 kV bus at existing Transmission Owner substation ("Cimarron 115kV Substation") that is owned and maintained by Transmission Owner;
- All transmission facilities required to connect the Interconnection Customer's substation to the POI;
- Equipment at the Interconnection Customer's substation necessary to maintain a composite power delivery at continuous rated power output at the high-side of the generator substation at a power factor within the range of 95% lagging and 95% leading in accordance with Federal Energy Regulatory Commission (FERC) Order 827. The Interconnection Customer may use inverter manufacturing options for providing reactive power under no/reduced generation conditions. The Interconnection Customer will be required to provide documentation and design specifications demonstrating how the requirements are met; and,
- All necessary relay, protection, control and communication systems required to protect Interconnection Customer's Interconnection Facilities and Generating Facilities and coordinate with Transmission Owner's relay, protection, control and communication systems.

TRANSMISSION OWNER INTERCONNECTION FACILITIES AND NON-SHARED NETWORK UPGRADE(S)

To facilitate interconnection, the interconnecting Transmission Owner will perform work as shown below necessary for the acceptance of the Interconnection Customer’s Interconnection Facilities.

Table 1 and **Table 2** lists the Interconnection Customer’s estimated cost responsibility for Transmission Owner Interconnection Facilities (TOIF) and Non-Shared Network Upgrade(s) and provides an estimated lead time for completion of construction. The estimated lead time begins when the Generator Interconnection Agreement has been fully executed.

Table 1: Transmission Owner Interconnection Facilities (TOIF)

Transmission Owner Interconnection Facilities (TOIF)	Total Cost Estimate (\$)	Allocated Percent (%)	Allocated Cost Estimate (\$)
<u>Transmission Owner's Cimarron 115kV Substation GEN-2018-009 Interconnection (TOIF) (SUNC) (UID155901): Facilitate the interconnection of GEN-2018-009 Estimated Lead Time: 33 Months</u>	\$738,203	100.00%	\$738,203
Total	\$738,203		\$738,203

Table 2: Non-Shared Network Upgrade(s)

Non-Shared Network Upgrades Description	ILTCR	Total Cost Estimate (\$)	Allocated Percent (%)	Allocated Cost Estimate (\$)
<u>Transmission Owner's Cimarron 115kV Substation Interconnection Expansion (DISIS-2018-001) (UID155902): Facilitate the interconnection of GEN-2018-009 Estimated Lead Time: 33 Months</u>	Ineligible	\$4,183,153	100.00%	\$4,183,153
Total		\$4,183,153		\$4,183,153

SHARED NETWORK UPGRADE(S)

The Interconnection Customer’s share of costs for Shared Network Upgrades is estimated in **Table 3** below.

Table 3: Interconnection Customer Shared Network Upgrade(s)

Shared Network Upgrades Description	ILTCR	Total Cost Estimate (\$)	Allocated Percent (%)	Allocated Cost Estimate (\$)
<u>N/A</u>				
Total		\$ 0		\$ 0

All studies have been conducted assuming that higher-queued Interconnection Request(s) and the associated Network Upgrade(s) will be placed into service. If higher-queued Interconnection Request(s) withdraw from the queue, suspend or terminate service, the Interconnection Customer’s share of costs may be revised. Restudies, conducted at the customer’s expense, will determine the Interconnection Customer’s revised allocation of Shared Network Upgrades.

CONTINGENT NETWORK UPGRADE(S)

Certain Contingent Network Upgrades are **currently not the cost responsibility** of the Interconnection Customer but will be required for full Interconnection Service.

Table 4: Interconnection Customer Contingent Network Upgrade(s)

Contingent Network Upgrade(s) Description	Current Cost Assignment	Estimated In-Service Date
Line - Wolf Creek - Blackberry 345 kV- Build a new 345kV line from Wolf Creek to Blackberry with a summer emergency rating of 1792 MVA. Install terminal equipment at Wolf Creek to support 345kV line from Wolf Creek to Blackberry rated at 1792 MVA (NTC - 210592/210626)	\$0	7/15/2025

Depending upon the status of higher- or equally-queued customers, the Interconnection Request's in-service date is at risk of being delayed or Interconnection Service is at risk of being reduced until the in-service date of these Contingent Network Upgrades.

AFFECTED SYSTEM UPGRADE(S)

To facilitate interconnection, the Affected System Transmission Owner will be required to perform the facilities study work as shown below necessary for the acceptance of the Interconnection Customer’s Interconnection Facilities. **Table 5** displays the current impact study costs provided by either MISO or AECI as part of the Affected System Impact review. The Affected System facilities study could provide revised costs and will provide each Interconnection Customer’s allocation responsibilities for the upgrades.

Table 5: Interconnection Customer Affected System Upgrade(s)

Affected System Upgrades Description	Total Cost Estimate (\$)	Allocated Percent (%)	Allocated Cost Estimate (\$)
<u>N/A</u>			
Total	\$0		\$0

CONCLUSION

After all Interconnection Facilities and Network Upgrades have been placed into service, Interconnection Service for 150 MW can be granted. Full Interconnection Service will be delayed until the TOIF, Non-Shared NU, Shared NU, Contingent NU, Affected System Upgrades that are required for full interconnection service are completed. The Interconnection Customer's estimated cost responsibility for full interconnection service is summarized in the table below.

Table 6: Cost Summary

Description	Allocated Cost Estimate
Transmission Owner Interconnection Facilities Upgrade(s)	\$738,203
Non-Shared Network Upgrade(s)	\$4,183,153
Shared Network Upgrade(s)	\$0
Affected System Upgrade(s)	\$0
Total	\$4,921,356

Use the following link for Quarterly Updates on upgrades from this report: <https://spp.org/spp-documents-filings/?id=18641>

A draft Generator Interconnection Agreement will be provided to the Interconnection Customer consistent with the final results of this IFS report. The Transmission Owner and Interconnection Customer will have 60 days to negotiate the terms of the GIA consistent with the SPP Open Access Transmission Tariff (OATT).

APPENDICES

**A: TRANSMISSION OWNER'S INTERCONNECTION FACILITIES STUDY
REPORT AND NETWORK UPGRADES REPORT(S)**

See next page for the Transmission Owner's Interconnection Facilities Study Report and Network Upgrades Report(s).

**Interconnection Facilities Study
for GEN-2018-009 Network Upgrades
and TOIF upgrades at the Cimmaron River 115 kV
Substation**

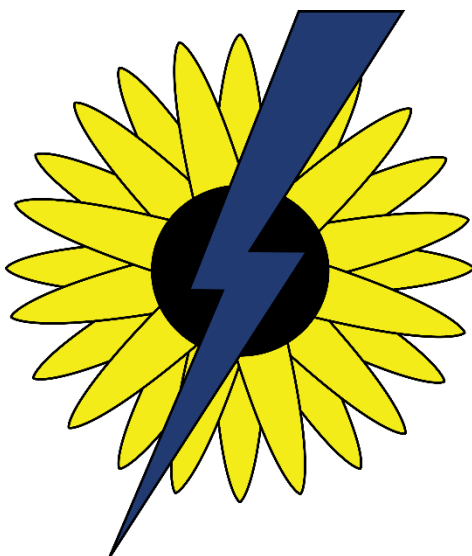

November 1, 2023

Interconnection Facilities Study – Cimarron River 115 kV Network Upgrades and TOIF

TABLE OF CONTENTS

Study Overview: 2
Interconnection Facilities and Non-Shared Network Upgrades: 2
Interconnection Costs:..... 4
Project Timeline: 4

Interconnection Facilities Study – Cimarron River 115 kV Network Upgrades and TOIF

STUDY OVERVIEW:

The Southwest Power Pool has requested a Facility Study for Interconnection Facilities and Network Upgrades from Sunflower Electric Power Corporation (Sunflower) at the Cimarron River 115 kV substation for request GEN-2018-009. The GEN-2018-009 request consists of a total of 150 MW of wind generation interconnecting to the Cimarron River 115 kV bus.

There Non-Shared Network Upgrades (NU) identified to accept a new generator lead include terminal equipment to accept a new line into the existing Sunflower 115 kV ring bus. The cost for these Network Upgrades is estimated as \$4,183,153.

The Transmission Owner Interconnection Facility (TOIF) addition identified is a new 115 kV generator lead connection into the existing 115 kV substation. The cost for adding the new 115 kV generator lead is estimated as \$738,203.

The purpose of this study is to provide estimated costs of facilities required for interconnection of the proposed generation to Sunflower's transmission system and to identify scope and estimated costs for network upgrades required on Sunflower's transmission system to allow the generation to run at the full requested capacity.

Additional network upgrades required for facilities of other transmission owners are not included in this study and will be identified by SPP.

INTERCONNECTION FACILITIES AND NON-SHARED NETWORK UPGRADES:

Non-shared Network Upgrades (NU) additions required by Sunflower consist of the addition of a single 115 kV line terminal, circuit breakers, PTs, disconnect switches, structures, foundations, conductors, insulators, and all other associated work and materials in the existing Sunflower Cimarron River 115 kV substation.

Transmission Owner Interconnection Facility (TOIF) additions required by Sunflower consist of revenue metering CTs and PTs, disconnect switch, protective relays, and terminal equipment needed to interconnect the customer's generator lead line to Sunflower's Cimarron River 115 kV substation.

This 115 kV ring bus addition at Cimarron River shall be constructed and maintained by Sunflower. It is assumed that obtaining all necessary right-of-way for the line into the Sunflower 115 kV substation facilities will be performed by the interconnection customer. The addition of generator 115 kV lead line from the customer substation into the existing Sunflower Cimarron River 115 kV substation and the step up transformer that connects to the customer's collector substation is not included and is the responsibility of the interconnection customer.

The proposed arrangement for interconnection of GEN-2018-009 is shown in Figure 1.

Interconnection Facilities Study – Cimarron River 115 kV Network Upgrades and TOIF

Figure 1: One-line Diagram Facilities for GEN-2018-009

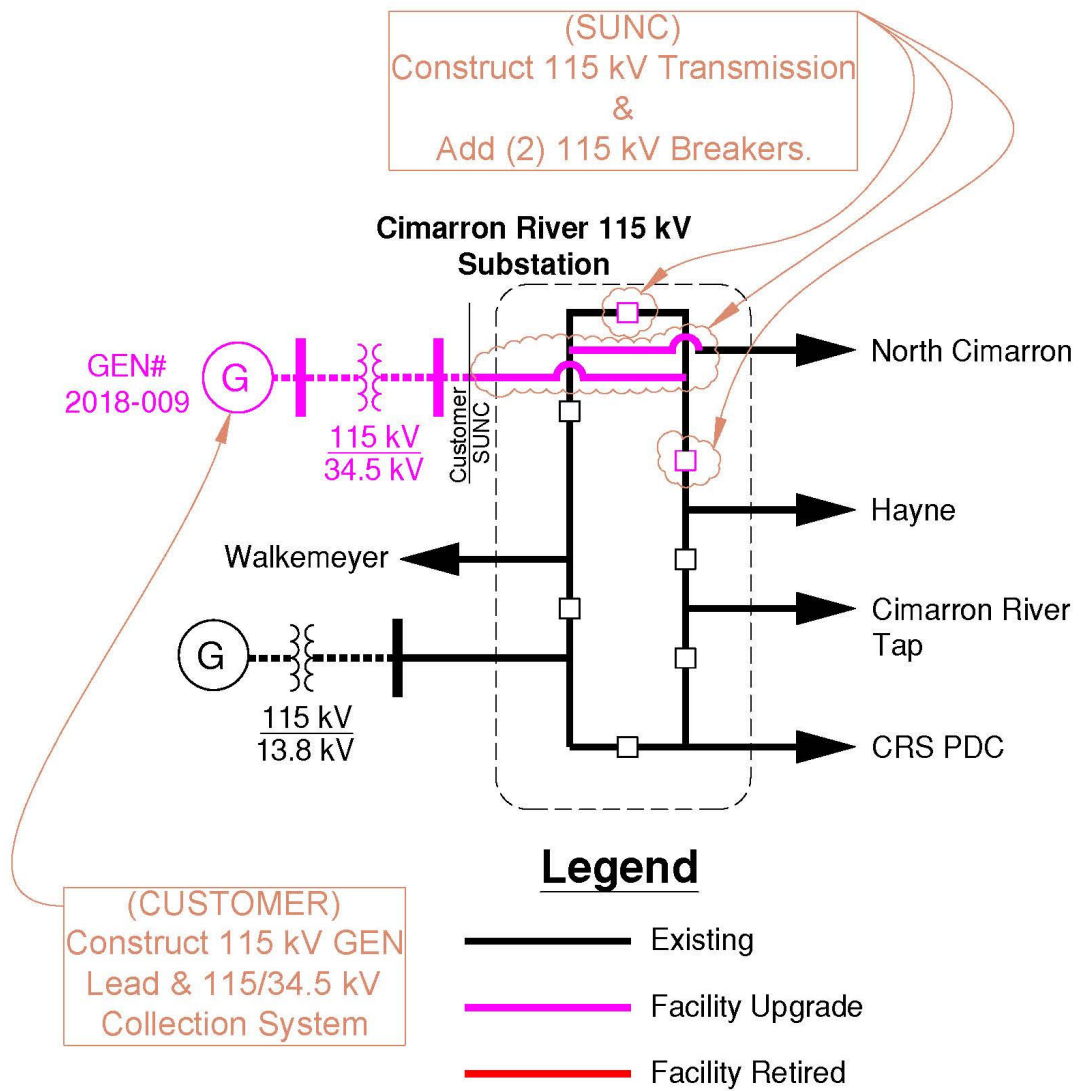

Interconnection Facilities Study – Cimarron River 115 kV Network Upgrades and TOIF

INTERCONNECTION COSTS:

Summary of interconnection costs for both Interconnection Facilities and Sunflower identified Network Upgrades can be found in the following table.

Facilities	Estimated Cost (2023 Dollars)
Transmission Owner Interconnection Facilities (TOIF) Construct one (1) line terminal addition in the existing Cimarron River 115 kV substation with revenue metering CTs and PTs, disconnect switch, protective relays, and terminal equipment needed to interconnect the customer’s generator lead line.	\$738,203
Non-shared Network Upgrades Construct the addition of a single 115 kV line terminal, two (2) 115 kV circuit breakers, PTs, disconnect switches, structures, foundations, conductors, insulators, and all other associated work and materials in the existing Sunflower Cimarron River 115 kV substation	\$4,183,153
Total Interconnection Cost:	\$4,921,356

PROJECT TIMELINE:

Specific construction schedule and milestones will be determined during the Generator Interconnection Agreement negotiations. Sunflower is estimating an engineering and construction schedule for this project as approximately 33 months. Other factors associated with clearances, equipment procurement delays and work schedules could cause additional delays. This is applicable after all required agreements are signed and internal approvals are granted.